

# SMART HOOK SLIM 48-51 | 30 | 50KG

CODE 5075-2 / 5075-2B



Eine Haken-Slim-Ausführung zum Einhängen an die Traverse mit einem Verschluss, der von unten greift.

A slim hook design for hanging devices on the truss with a lock which grips from underneath/below.

Kompatibel | compatible  
 Breite | width  
 Zugbelastung | tensile load  
 Abgang | retaining screw

48-51 mm  
 30 mm  
 50 kg  
 M10 Flügelmutter,  
 Sprengring, Unterlagsscheibe  
 M10 screw, spring-lock, washer

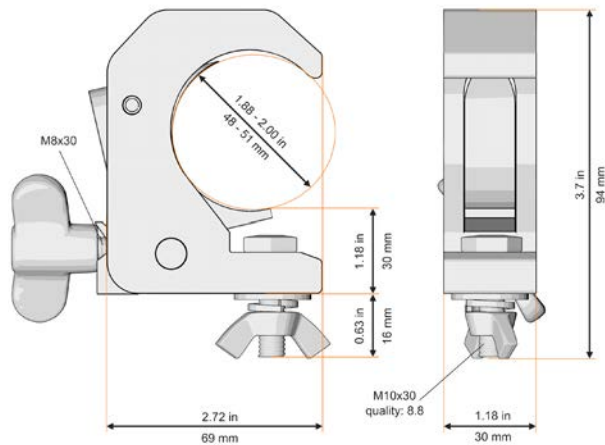

## KOMPATIBILITÄT | COMPATIBILITY



F52 Folding



F54



F44



F44P



F34



F34P



F34PL



F34QX



F24



F43



F33



F33PL



M25AS



F23



F42



F32



F22



F31



F31PL